

Type 1

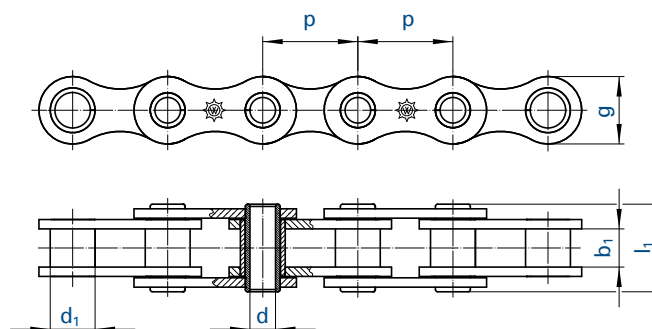

Type 2

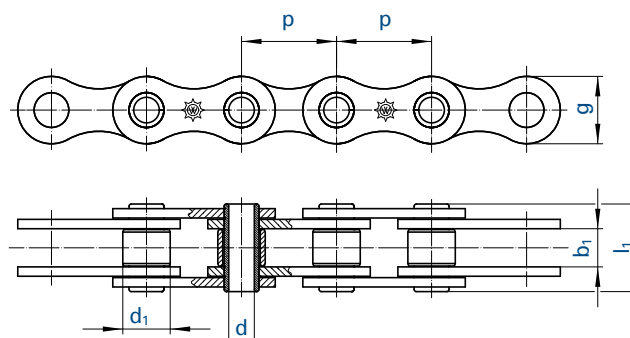

Type 3

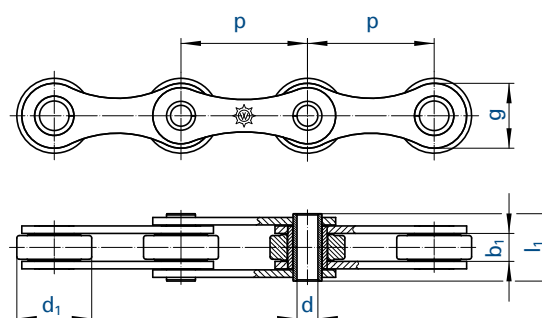

| Chain   |                  | Pitch  |       | Inner width         | Roller (Bushing) Ø  | Hollow pin |                | Plate height | Type | Bearing area    | Breaking load       | Weight |
|---------|------------------|--------|-------|---------------------|---------------------|------------|----------------|--------------|------|-----------------|---------------------|--------|
| ⚙️      |                  | p      |       | b <sub>1</sub> min. | d <sub>1</sub> max. | Bore Ø     | Width          | g max.       |      | f               | F <sub>B</sub> min. | q ≈    |
| No.     | Ind.             | mm     | inch  | mm                  | mm                  | d +0,1     | l <sub>1</sub> | mm           |      | cm <sup>2</sup> | kN                  | kg/m   |
| 01105   |                  | 12,700 | 1/2   | 3,30                | 7,75                | 4,2        | 10,2           | 10,5         | 2    | 0,14            | 10,0                | 0,34   |
| 01462   |                  | 12,700 | 1/2   | 7,75                | 8,51                | 4,0        | 17,0           | 12,2         | 1    | 0,68            | 10,0                | 0,65   |
| 01463   |                  | 12,700 | 1/2   | 9,50                | 8,51                | 4,0        | 19,0           | 11,8         | 2    | 0,20            | 14,0                | 0,68   |
| 01500   |                  | 15,875 | 5/8   | 6,50                | 10,16               | 5,0        | 17,0           | 14,7         | 2    | 0,28            | 15,0                | 0,74   |
| 01501   |                  | 15,875 | 5/8   | 9,50                | 10,16               | 5,0        | 20,0           | 14,7         | 2    | 0,28            | 15,0                | 0,83   |
| 01513   |                  | 19,050 | 3/4   | 11,70               | 12,07               | 5,0        | 22,5           | 16,1         | 2    | 0,30            | 25,0                | 1,07   |
| 01589   |                  | 38,100 | 1 1/2 | 15,20               | 18,00               | 10,2       | 34,5           | 28,0         | 1    | 2,28            | 45,0                | 2,62   |
| 01598   | <sup>1,3</sup>   | 50,000 | -     | 15,00               | 26,00               | 14,4       | 35,6           | 40,0         | 1    | 4,20            | 100,0               | 4,10   |
| 01650   | <sup>4,5</sup>   | 50,800 | 2     | 11,00               | 30,00               | 8,2        | 27,0           | 26,0         | 3    | 1,94            | 50,0                | 2,15   |
| 01650RF | <sup>4,5,6</sup> | 50,800 | 2     | 11,00               | 30,00               | 8,2        | 27,0           | 26,0         | 3    | 1,94            | 32,0                | 2,15   |

Electrogalvanised or nickel-plated chains on request. In this case chains may only have 80 % of the tensile strength.

<sup>1</sup> with straight side plates    <sup>3</sup> also supplied with small rollers 32 mm Ø (Type 3)    <sup>4</sup> also with plastic rollers    <sup>5</sup> support rollers    <sup>6</sup> made of stainless and acid resistant steel W.-No. 1.4301

For details on orders and enquiries see page 131. Sprockets on request.  
Information on the selection of chain sizes and drives as of page 118.

Hollow pin chains are to be connected by means of outer links (pin links). For the chains No. 01597 and No. 01598 straight connecting links with Seeger circlip ring can be supplied.